

COBRA

PRO, TT, TT-AWD

Safety and operating instructions

Petrol breakers

Valid for United States of America only

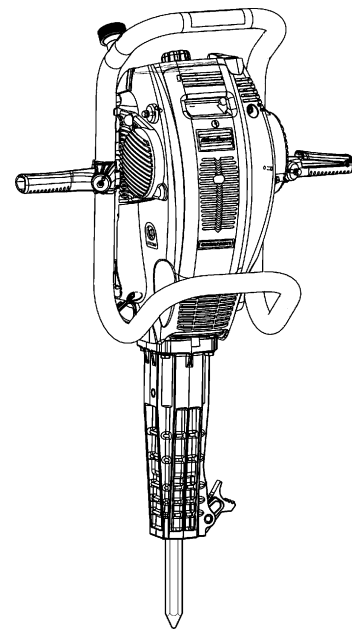

Contents

Introduction.....	5
About the Safety and operating instructions.....	5
Safety instructions.....	6
Safety signal words.....	6
Personal precautions and qualifications.....	6
Personal protective equipment.....	6
Drugs, alcohol or medication.....	6
Installation, precautions.....	6
Operation, precautions.....	6
Maintenance, precautions.....	10
Storage, precautions.....	11
Overview.....	12
Design and function.....	12
Choosing the correct breaker for a task.....	12
Main parts.....	12
Labels.....	13
Data plate.....	13
Noise level label.....	13
Warning label.....	13
Emission compliance label.....	13
Transport.....	14
Installation.....	14
Fuel.....	14
Two-stroke oil.....	14
Mixing the petrol and oil.....	14
Filling.....	14
AWD - Audio Warning Device.....	14
Insertion tool.....	15
Selecting the right insertion tool.....	15
Narrow chisel.....	15
Moil point.....	15
Wide bladed chisel.....	15
Checking for wear on the tool shank.....	16
Operation.....	16
Start and stop.....	16
Cold start.....	16
Restarting a warm machine.....	16
Restarting an overheated machine.....	16
Stopping.....	16
Operating.....	16
Starting a cut.....	16
Breaking.....	17
Breaking at high altitude.....	17
Tie tamping.....	17
When taking a break.....	17
Maintenance.....	17
Every day.....	18
Wear check.....	18
Air filter check.....	18

Spark plug check.....	18
Hammer mechanism oil check.....	18
Every month.....	19
Gearbox oil level check.....	19
Every year.....	19
Repair.....	19
Replacing the starter cord.....	19
Troubleshooting.....	20
Storage.....	21
Disposal.....	21
Technical data.....	22
Products.....	22
Machine data.....	22
Gearbox unit.....	22
Impact unit.....	23
Noise and vibration declaration statement.....	23
Additional vibration information.....	23
Noise and vibration data.....	24
EC Declaration of Conformity.....	25
EC Declaration of Conformity (EC Directive 2006/42/EC).....	25
Warranty.....	26
Emission control system warranty.....	26
General warranty conditions and limitations on liability.....	27

Introduction

Thank you for choosing a product from Atlas Copco. Since 1873, we have been committed to finding new and better ways of fulfilling our customers' needs. Through the years, we have developed innovative and ergonomic product designs that have helped customers improve and rationalize their daily work.

Atlas Copco has a strong global sales and service network, consisting of customer centers and distributors worldwide. Our experts are highly trained professionals with extensive product knowledge and application experience. In all corners of the world, we can offer product support and expertise to ensure that our customers can work at maximum efficiency at all times.

For more information please visit: www.atlascopco.com

Atlas Copco Construction Tools AB
105 23 Stockholm
Sweden

About the Safety and operating instructions

The aim of the instructions is to provide you with knowledge of how to use the petrol breaker in an efficient, safe way. The instructions also give you advice and tell you how to perform regular maintenance on the petrol breaker.

Before using the petrol breaker for the first time you must read these instructions carefully and understand all of them.

Safety instructions

To reduce the risk of serious injury or death to yourself or others, read and understand the Safety and operating instruction before installing, operating, repairing, maintaining, or changing accessories on the machine.

Post this Safety and operating instruction at work locations, provide copies to employees, and make sure that everyone reads the Safety and operating instruction before operating or servicing the machine.

In addition, the operator or the operator's employer must assess the specific risks that may be present as a result of each use of the machine.

Safety signal words

The safety signal words Danger, Warning and Caution have the following meanings:

DANGER	Indicates a hazardous situation which, if not avoided, will result in death or serious injury.
WARNING	Indicates a hazardous situation which, if not avoided, could result in death or serious injury.
CAUTION	Indicates a hazardous situation which, if not avoided, could result in minor or moderate injury.

Personal precautions and qualifications

Only qualified and trained persons may operate or maintain the machine. They must be physically able to handle the bulk, weight, and power of the tool. Always use your common sense and good judgement.

Personal protective equipment

Always use approved protective equipment. Operators and all other persons in the working area must wear protective equipment, including at a minimum:

- Protective helmet
- Hearing protection
- Impact resistant eye protection with side protection
- Respiratory protection when appropriate
- Protective gloves
- Proper protective boots
- Appropriate work overall or similar clothing (not loose-fitting) that covers your arms and legs.

Drugs, alcohol or medication

▲ **WARNING** Drugs, alcohol or medication

Drugs, alcohol or medication may impair your judgment and powers of concentration. Poor reactions and incorrect assessments can lead to severe accidents or death.

- ▶ Never use the machine when you are tired or under the influence of drugs, alcohol or medication.
- ▶ No person who is under the influence of drugs, alcohol or medication may operate the machine.

Installation, precautions

▲ **WARNING** Ejected insertion tool

If the tool retainer on the machine is not in a locked position, the inserted tool can be ejected with force, which can cause personal injury.

- ▶ Always stop the machine before changing the inserted tool or accessories.
- ▶ Never point the inserted tool at yourself or anyone else.
- ▶ Make sure that the insertion tool is fully inserted and the tool retainer is in a locked position before the machine is started.
- ▶ Check the lock function by pulling the inserted tool outwards powerfully.

▲ **WARNING** Moving or slipping insertion tool

An incorrect dimension of the inserted tool's shank can result in that the inserted tool is lost or is slipping out during operation. Risk of severe injury or crushed hands and fingers.

- ▶ Check that the insertion tool has the shank length and dimensions that the machine is intended for.
- ▶ Never use an insertion tool without a collar.

Operation, precautions

▲ **DANGER** Explosion hazard

If a warm insertion tool or exhaust pipe comes into contact with explosives, an explosion could occur. During operating with certain materials, sparks and ignition can occur. Explosions will lead to severe injuries or death.

- ▶ Never operate the machine in any explosive environment.
- ▶ Never use the machine near flammable materials, fumes or dust.
- ▶ Make sure that there are no undetected sources of gas or explosives.

- ▶ Avoid contact with the warm exhaust pipe or the bottom of the machine.

▲ DANGER Fuel hazard

The fuel (petrol and oil) is extremely flammable and petrol fumes can explode when ignited, causing serious injury or death.

- ▶ Protect your skin from contact with the fuel. If fuel has penetrated the skin, consult a qualified health professional.
- ▶ Never remove the filler cap, and never fill the fuel tank when the machine is hot.
- ▶ Mix the fuel and fill the fuel tank outdoors or in a clean and well ventilated place, free from sparks and open flames. Fill the fuel tank at least ten meters (30 feet) from the place where the machine is to be used.
- ▶ Release the filler cap slowly to let pressure escape.
- ▶ Never overfill the fuel tank.
- ▶ Make sure the filler cap is screwed on when the machine is used.
- ▶ Avoid spilling fuel on the machine, wipe off any spilled fuel.
- ▶ Check regularly for fuel leaks. Never use the machine if it is leaking fuel.
- ▶ Never use the machine in the proximity of material that can generate sparks. Remove all hot or spark-generating devices before starting the machine.
- ▶ Never smoke when filling the fuel tank or when working with the machine or servicing it.
- ▶ Only store fuel in a container that is specially constructed and approved for the purpose.
- ▶ Consumed petrol and oil containers must be taken care of and returned to the retailer.
- ▶ Never use your fingers to check for fluid leaks.

▲ WARNING Unexpected movements

The inserted tool is exposed to heavy strains when the machine is used. The inserted tool may break due to fatigue after a certain amount of use. If the inserted tool breaks or gets stuck, there may be sudden and unexpected movement that can cause injuries. Furthermore, losing your balance or slipping may cause injury.

- ▶ Make sure that you always keep a stable position with your feet as far apart as your shoulder width, and keeping a balanced body weight.
- ▶ Always inspect the equipment prior to use. Never use the equipment if you suspect that it is damaged.
- ▶ Make sure that the handles are clean and free of grease and oil.
- ▶ Keep your feet away from the inserted tool.
- ▶ Stand firmly and always hold on to the machine with both hands.
- ▶ Never start the machine when it is lying on the ground.
- ▶ Never 'ride' on the machine with one leg over the handle.
- ▶ Never strike or abuse the equipment.
- ▶ Check regularly for wear on the insertion tool, and check whether there are any signs of damage or visible cracks.
- ▶ Pay attention and look at what you are doing.

▲ WARNING Dust and fume hazard

Dusts and/or fumes generated or dispersed when using the machine may cause serious and permanent respiratory disease, illness, or other bodily injury (for example, silicosis or other irreversible lung disease that can be fatal, cancer, birth defects, and/or skin inflammation).

Some dusts and fumes created by drilling, breaking, hammering, sawing, grinding and other construction activities contain substances known to the State of California and other authorities to cause respiratory disease, cancer, birth defects, or other reproductive harm. Some examples of such substances are:

- Crystalline silica, cement, and other masonry products.
- Arsenic and chromium from chemically-treated rubber.
- Lead from lead-based paints.

Dust and fumes in the air can be invisible to the naked eye, so do not rely on eye sight to determine if there is dust or fumes in the air.

To reduce the risk of exposure to dust and fumes, do all of the following:

- ▶ Perform site-specific risk assessment. The risk assessment should include dust and fumes created by the use of the machine and the potential for disturbing existing dust.
- ▶ Use proper engineering controls to minimize the amount of dust and fumes in the air and to minimize build-up on equipment, surfaces, clothing, and body parts. Examples of controls include: exhaust ventilation and dust collection systems, water sprays, and wet drilling. Control dusts and fumes at the source where possible. Make sure that controls are properly installed, maintained and correctly used.
- ▶ Wear, maintain and correctly use respiratory protection as instructed by your employer and as required by occupational health and safety regulations. The respiratory protection must be effective for the type of substance at issue (and if applicable, approved by relevant governmental authority).
- ▶ Work in a well ventilated area.
- ▶ If the machine has an exhaust, direct the exhaust so as to reduce disturbance of dust in a dust filled environment.
- ▶ Operate and maintain the machine as recommended in the operating and safety instructions

- ▶ Select, maintain and replace consumables/ inserted tools/ other accessory as recommended in the operating and safety instructions. Incorrect selection or lack of maintenance of consumables/ inserted tools/ other accessories may cause an unnecessary increase in dust or fumes.
- ▶ Wear washable or disposable protective clothes at the worksite, and shower and change into clean clothes before leaving the worksite to reduce exposure of dust and fumes to yourself, other persons, cars, homes, and other areas.
- ▶ Avoid eating, drinking, and using tobacco products in areas where there is dust or fumes.
- ▶ Wash your hands and face thoroughly as soon as possible upon leaving the exposure area, and always before eating, drinking, using tobacco products, or making contact with other persons.
- ▶ Comply with all applicable laws and regulations, including occupational health and safety regulations.
- ▶ Participate in air monitoring, medical examination programs, and health and safety training programs provided by your employer or trade organizations and in accordance with occupational health and safety regulations and recommendations. Consult with physicians experienced with relevant occupational medicine.
- ▶ Work with your employer and trade organization to reduce dust and fume exposure at the worksite and to reduce the risks. Effective health and safety programs, policies and procedures for protecting workers and others against harmful exposure to dust and fumes should be established and implemented based on advice from health and safety experts. Consult with experts.

▲ DANGER Exhaust gas hazard

The exhaust gas from the machine's combustion engine contains carbon monoxide which is poisonous, and chemicals known to the State of California and other authorities to cause cancer, birth defects, or other reproductive harm. Inhalation of exhaust fumes can cause serious injury, illness, or death.

- ▶ Never inhale exhaust fumes.
- ▶ Never operate the machine indoors or in a poorly ventilated area.
- ▶ Never stand in a deep hole, ditch, or similar surrounding during operating.

▲ WARNING Projectiles

Failure of the work piece, of accessories, or even of the machine itself may generate high velocity projectiles. During operating, splinters or other particles from the working material may become projectiles and cause personal injury by striking the operator or other persons. To reduce these risk:

- ▶ Use approved personal protective equipment and safety helmet, including impact resistant eye protection with side protection.
- ▶ Make sure that no unauthorised persons trespass into the working zone.
- ▶ Keep the workplace free from foreign objects.
- ▶ Ensure that the work piece is securely fixed.

▲ WARNING Splinters hazard

Using the insertion tool as a hand struck tool can result in splinters hitting the operator and can cause personal injury.

- ▶ Never use a insertion tool as a hand struck tool. They are specifically designed and heat-treated to be used only in a machine.

▲ WARNING Slipping, tripping and falling hazards

There is a risk of slipping or tripping or falling, for example tripping on the hoses or on other objects. Slipping or tripping or falling can cause injury. To reduce this risk:

- ▶ Always make sure that no hose or other object is in your way or in any other person's way.
- ▶ Always make sure you are in a stable position with your feet as far apart as your shoulders width and keeping a balanced body weight.

▲ WARNING Motion hazards

When using the machine to perform work-related activities, you may experience discomfort in the hands, arms, shoulders, neck, or other parts of the body.

- ▶ Adopt a comfortable posture whilst maintaining secure footing and avoiding awkward off-balanced postures.
- ▶ Changing posture during extended tasks may help avoid discomfort and fatigue.
- ▶ In case of persistent or recurring symptoms, consult a qualified health professional.

▲ WARNING Vibration hazards

Normal and proper use of the machine exposes the operator to vibration. Regular and frequent exposure to vibration may cause, contribute to, or aggravate injury or disorders to the operator's fingers, hands, wrists, arms, shoulders and/or nerves and blood supply or other body parts, including debilitating and/or permanent injuries or disorders that may develop gradually over periods of weeks, months, or years. Such injuries or disorders may include damage to the blood circulatory system, damage to the nervous system, damage to joints, and possibly damage to other body structures.

If numbness, persistent recurring discomfort, burning sensation, stiffness, throbbing, tingling, pain, clumsiness, weakened grip, whitening of the skin, or other symptoms occur at any time, when operating the machine or when not operating the machine, stop operating the machine, tell your employer and seek medical attention. Continued use of the machine after the occurrence of any such symptom may increase the risk of symptoms becoming more severe and/or permanent.

Operate and maintain the machine as recommended in these instructions, to prevent an unnecessary increase in vibration.

The following may help to reduce exposure to vibration for the operator:

- ▶ Let the tool do the job. Use a minimum hand grip consistent with proper control and safe operation.
- ▶ If the machine has vibration absorbing handles, keep them in a central position, avoid pressing the handles into the end stops.
- ▶ When the percussion mechanism is activated, the only body contact with the machine you should have are your hands on the handle or handles. Avoid any other contact, for example supporting any part of the body against the machine or leaning onto the machine trying to increase the feed force. It is also important not to keep the start and stop device engaged while extracting the tool from the broken work surface.
- ▶ Make sure that the inserted tool is well-maintained (including sharpness, if a cutting tool), not worn out, and of the proper size. Insertion tools that are not well-maintained, or that are worn out, or that are not of the proper size result in longer time to complete a task (and a longer period of exposure to vibration) and may result in or contribute to higher levels of vibration exposure.
- ▶ Immediately stop working if the machine suddenly starts to vibrate strongly. Before resuming the work, find and remove the cause of the increased vibrations.
- ▶ Never grab, hold or touch the inserted tool when using the machine.

- ▶ Participate in health surveillance or monitoring, medical exams and training programs offered by your employer and when required by law.
- ▶ When working in cold conditions wear warm clothing and keep hands warm and dry.

See the "Noise and vibration declaration statement" for the machine, including the declared vibration values. This information can be found at the end of these Safety and operating instructions.

▲ DANGER Electrical hazard

The machine is not electrically insulated. If the machine comes into contact with electricity, serious injuries or death may result.

- ▶ Never operate the machine near any electric wire or other source of electricity.
- ▶ Make sure that there are no concealed wires or other sources of electricity in the working area.

▲ WARNING Concealed object hazard

During operating, concealed wires and pipes constitute a danger that can result in serious injury.

- ▶ Check the composition of the material before operating.
- ▶ Watch out for concealed cables and pipes for example electricity, telephone, water, gas and sewage lines etc.
- ▶ If the inserted tool seems to have hit a concealed object, switch off the machine immediately.
- ▶ Make sure that there is no danger before continuing.

▲ WARNING Involuntary start

Involuntary start of the machine may cause injury.

- ▶ Keep your hands away from the start and stop device until you are ready to start the machine.
- ▶ Learn how the machine is switched off in the event of an emergency.

▲ WARNING Noise hazard

High noise levels can cause permanent and disabling hearing loss and other problems such as tinnitus (ringing, buzzing, whistling, or humming in the ears). To reduce risks and prevent an unnecessary increase in noise levels:

- ▶ Risk assessment of these hazards and implementation of appropriate controls is essential.
- ▶ Operate and maintain the machine as recommended in these instructions.
- ▶ Select, maintain and replace the insertion tool as recommended in these instructions.
- ▶ If the machine has a silencer, check that it is in place and in good working condition.

- ▶ Always use hearing protection.
- ▶ Use damping material to prevent work pieces from 'ringing'.

▲ WARNING Unstable position hazard

During operation of the machine, there is a risk for falling, tripping and/or coming in contact with the inserted tool, which can cause injury. This risk increases if you work in an unstable position or on any unstable ground, object or surface. To reduce this risk:

- ▶ Never work in an unstable position.
- ▶ Always make sure you are in a stable position with your feet as far apart as your shoulder width and keeping a balanced body weight.
- ▶ Never stand on any unstable ground, objects or surfaces.

▲ WARNING Slippery machine surface hazard

There is a risk that the machine (for example, the handle and other surfaces) is slippery due to grease, oil, or other substances. If the machine is slippery, there is a risk that you might lose your grip, drop the machine, and/or come in contact with the inserted tool during operation of the machine. Any such event can cause injury. To reduce this risk:

- ▶ Always make sure that the handles and other gripping surfaces of the machine are not slippery.
- ▶ Always make sure that the handles and other gripping surfaces are free from grease and oil.

Maintenance, precautions

▲ WARNING Machine modification

Any machine modification may result in bodily injuries to yourself or others.

- ▶ Never modify the machine. Modified machines are not covered by warranty or product liability.
- ▶ Always use original parts, insertion tools and accessories approved by Atlas Copco.
- ▶ Change damaged parts immediately.
- ▶ Replace worn components in good time.

▲ CAUTION High temperature

The machine's front cover, exhaust pipe, and bottom become hot during operation. Touching it can lead to burns.

- ▶ Never touch a hot front cover.
- ▶ Never touch the hot exhaust pipe.
- ▶ Never touch the bottom of the machine when its hot.

- ▶ Wait until the front cover, exhaust pipe, and bottom of the machine has cooled down before carrying out maintenance work.

▲ CAUTION Hot insertion tool

The tip of the insertion tool can become hot and sharp when used. Touching it can lead to burns and cuts.

- ▶ Never touch a hot or sharp insertion tool.
- ▶ Wait until the insertion tool has cooled down before carrying out maintenance work.

Storage, precautions

- ◆ Keep the machine and tools in a safe place, out of the reach of children and locked up.

Overview

To reduce the risk of serious injury or death to yourself or others, read the Safety instructions section found on the previous pages of this manual before operating the machine.

Design and function

Cobra Pro is designed for medium to heavy demolition of material such as concrete and asphalt.

Cobra TT and TT-AWD are designed for tie tamping and can also be used for medium demolition of material such as asphalt.

The petrol breaker is designed for vertical use only. No other use is permitted.

To choose the correct insertion tool, check the tool shank dimension on the machine, and see the spare parts list.

Choosing the correct breaker for a task

It is important to choose the correct size of breaker for the work to be performed.

A breaker that is too small means that the work will take longer.

A breaker that is too large means that there must be frequent repositioning, which is unnecessarily tiring for the operator.

A simple rule for choosing the correct size of breaker is that a normal sized piece of broken material should be removed from the workpiece within 10–20 seconds operation.

- If it takes less than 10 seconds a smaller breaker should be selected.
- If it takes more than 20 seconds a larger breaker should be selected.

Main parts

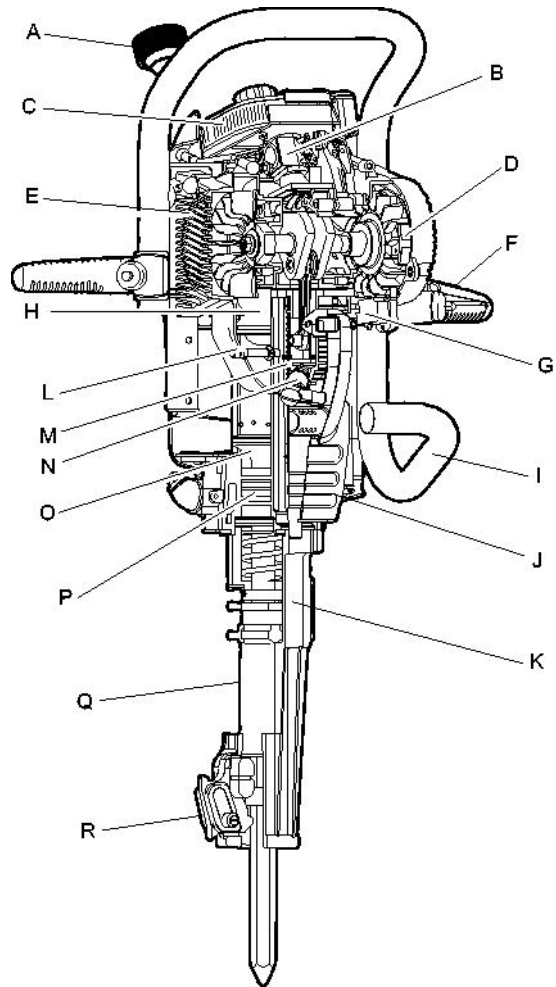

- A. Fuel filler cap
- B. Carburettor
- C. Air filter
- D. Flywheel
- E. Fan cover
- F. Throttle lever
- G. Ignition coil
- H. Drive piston
- I. Fuel tank
- J. Silencer
- K. Chisel fixture
- L. Decompression valve
- M. Engine piston
- N. Spark plug
- O. Hammer piston
- P. Hammer piston guide
- Q. Tool sleeve

R. Tool retainer

Labels

The machine is fitted with labels containing important information about personal safety and machine maintenance. The labels shall be in such condition that they are easy to read. New labels can be ordered from the spare parts list.

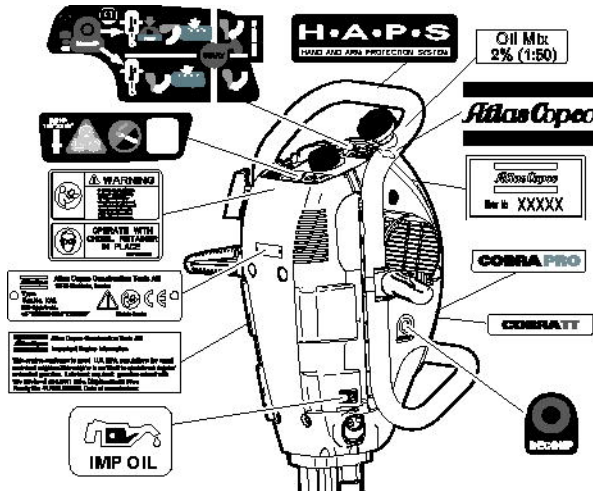

Data plate

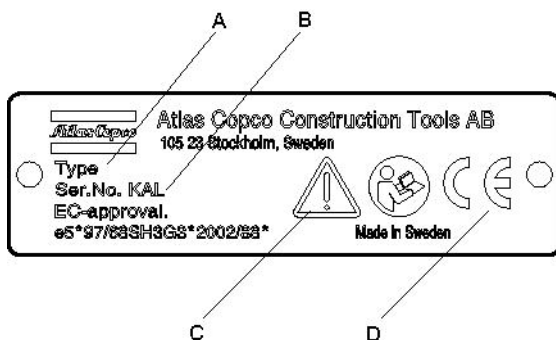

- A. Machine type
- B. Serial number
- C. The warning symbol together with the book symbol means that the user must read the Safety and operating instructions before the machine is used for the first time.
- D. The CE symbol means that the machine is EC-approved. See the EC Declaration of Conformity which is delivered with the machine for more information.

Noise level label

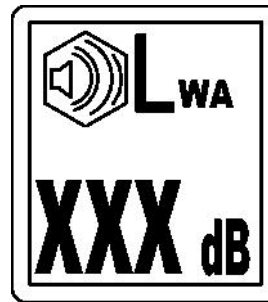

The label indicates the guaranteed noise level corresponding to EC-directive 2000/14/EC. See "Technical data" for accurate noise level.

Warning label

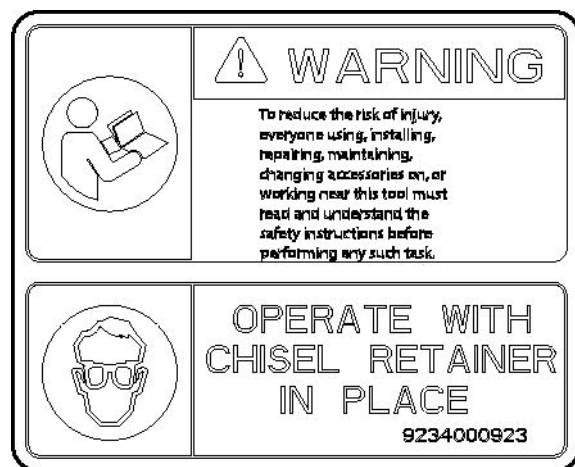

To reduce the risk of injury, everyone using, installing, repairing, maintaining, changing accessories on, or working near this tool must read and understand the safety instructions before performing any such task.

Operate with chisel retainer in place.

Emission compliance label

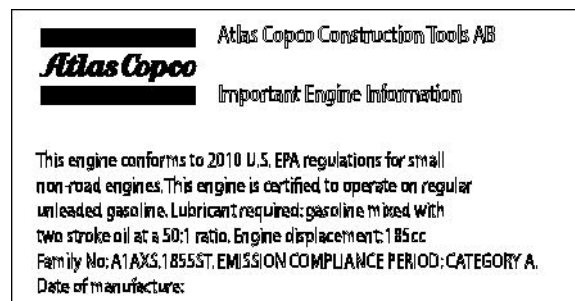

Emissions compliance period referred to on the label indicates the number of operating hours for which the engine has been shown to meet Federal emissions requirements.

Category C = 50 hours, B = 125 hours, and A = 300 hours.

Transport

▲ WARNING Fuel hazard

- ▶ Empty the tank before transport.

Installation

Fuel

Two-stroke oil

The fuel is petrol with a 2% oil mixture (1 part oil to 50 parts petrol). Always use high quality lead-free petrol (non-alkylat).

For the best lubricating results use Atlas Copco's environmentally friendly two-stroke oil, which has been specially developed for Atlas Copco's petrol engined hammering and rock-drilling machines.

If Atlas Copco's two-stroke oil is not available, use a high quality two-stroke oil for air-cooled engines (not two-stroke oil for outboard engines). Contact your local Atlas Copco representative for advice on the correct two-stroke oil.

Mixing the petrol and oil

Always mix the petrol and oil in a clean petrol can. First add the oil and then the correct amount of petrol. Then shake the can thoroughly. Shake the can before every refilling.

NOTICE During long term storage of two-stroke mixture, the oil and petrol can separate. Never mix more fuel than you intend to use within two weeks.

Filling

▲ WARNING Fuel hazard

The fuel (petrol and oil) is extremely flammable and petrol fumes can explode when ignited, causing serious injury or death.

- ▶ Protect your skin from contact with the fuel.
- ▶ Never remove the filler cap and do not fill the fuel tank when the machine is hot.
- ▶ Never smoke when filling the fuel tank or when working with the machine or servicing it.
- ▶ Avoid spilling fuel and wipe off any fuel spilled on the machine.

Filling procedure

1. Stop the engine and let it cool down before filling the tank.
2. The machine must be in a upright position when filling it with fuel.

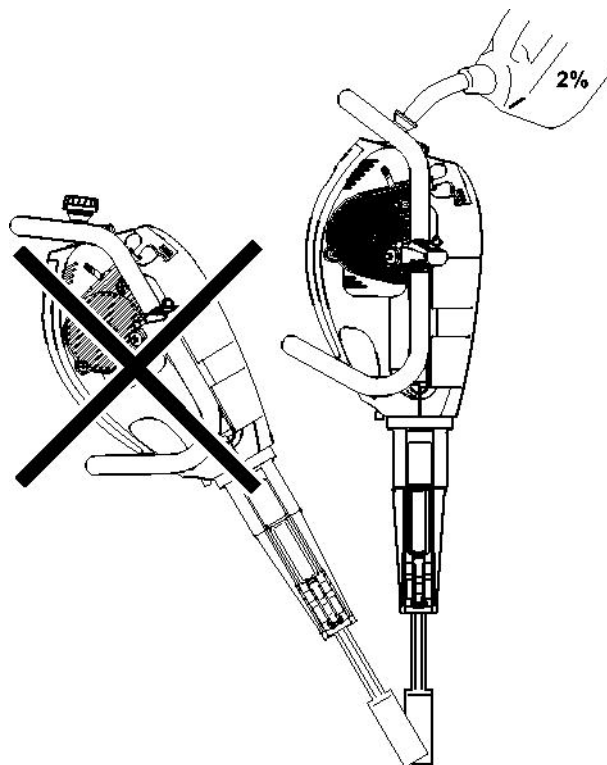

3. Release the filler cap slowly to let any pressure escape.
4. Never overfill the tank. It is possible due to the movement of the fuel within the tank to have fuel at a higher level than the tank cap, which can lead to a spillage of fuel if the tank cap is opened. This can be avoided by opening the tank cap, only when the machine is tilted and the tank cap is at the fuel tanks highest point.
5. Make sure that the filler cap is screwed on when the machine is used.

AWD - Audio Warning Device

Only valid for the model Cobra TT-AWD

The machine is prepared for Audio Warning Device, if it has an electrical outlet (A) on the left side of the front cover.

▲ DANGER Run over

If the stop function is not working, it can result in serious injuries or death.

- ▶ Before using the Audio Warning Device test the function of the warning equipment.
- ▶ If the stop function is not working, contact your nearest authorised workshop.

Checking the stop function

1. Check that plug (B) is fitted to outlet (A), so the machine is in order to start.
2. Start the machine and then pull out the plug (B). The machine shall stop immediately. If the machine does not stop when the plug (B) is removed, it must under no circumstances be used together with Audio Warning device. For further instructions contact your nearest authorised workshop.

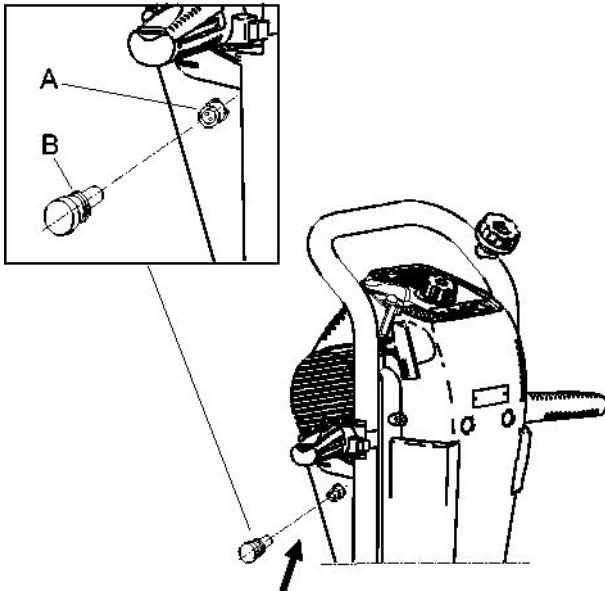
**Insertion tool****▲ CAUTION Hot insertion tool**

The tip of the insertion tool can become hot and sharp when used. Touching it can lead to burns and cuts.

- ▶ Never touch a hot or sharp insertion tool.
- ▶ Wait until the insertion tool has cooled down before carrying out maintenance work.

NOTICE Never cool a hot insertion tool in water, it can result in brittleness and early failure.

Selecting the right insertion tool

Selecting the right insertion tool is a precondition for proper machine function. It is important to select insertion tools of high quality to avoid unnecessary machine damage.

The machine can be destroyed if you use an incorrect insertion tool.

Recommended insertion tools are listed in the machine's spare parts list.

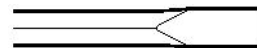
Narrow chisel

The narrow chisel is used for demolition and cutting work in concrete and other types of hard materials.

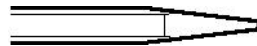
Moil point

The moil point is only used for making holes in concrete and other types of hard materials.

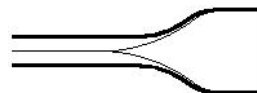
Wide bladed chisel

The wide bladed chisel is used in soft materials, such as asphalt and frozen ground.

▲ WARNING Vibration hazard

Using inserted tools that do not fulfil the criterias mentioned below, will result in a longer time to complete a task, and may result in higher levels of vibration exposure. A worn tool will also cause increased working time.

- ▶ Make sure that the inserted tool is well-maintained, not worn out and of the proper size.
- ▶ Always use a sharp tool in order to work efficiently.

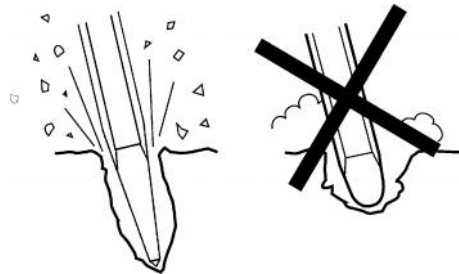

Checking for wear on the tool shank

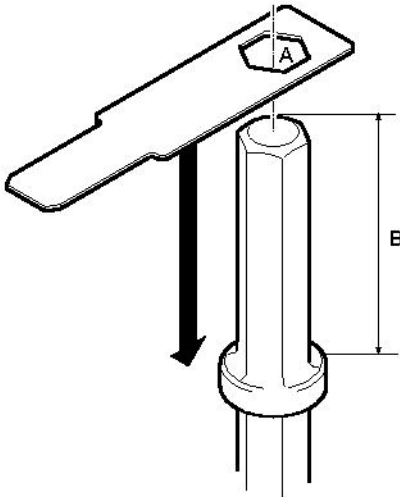

Use the gauge that corresponds to the insertion tool's shank dimension. See section "Technical data" for correct tool shank dimensions.

- Check if the gauge's hole (A) can be pushed down on the insertion tool's shank, this means that the shank is worn out and the insertion tool should be replaced.
- Check the length (B), that it is according to the ordered machine type.

Operation

▲ WARNING Involuntary start

Involuntary start of the machine may cause injury.

- ▶ Keep your hands away from the start and stop device until you are ready to start the machine.
- ▶ Learn how the machine is switched off in the event of an emergency.

Start and stop

Cold start

1. Slide the start button on the left handle backwards.
2. Close the choke by turning the choke control upwards.
3. Pump 5 times on the primer pump.
4. Press the decompression knob on the right side of the engine cylinder.
5. Depress the throttle lever to full throttle and pull on the starter handle.

6. When the machine starts, open the choke by turning the choke control downwards.
7. Warm up the engine for 2–3 minutes.

Restarting a warm machine

1. Press the decompression knob.
2. Do not touch the throttle lever.
3. Check that the choke is open and pull on the starter handle.

Restarting an overheated machine

If a hot engine stops after a short while, it can be due to vapour lock. Use the following restart procedure:

1. Press the decompression knob.
2. Close the choke by turning the choke control upwards.
3. Depress the throttle lever to full throttle and pull on the starter handle.
4. When the machine starts, let it run for few seconds then open the choke gradually to fully open (this can take up to 30 seconds).

Stopping

1. Stop the machine by sliding the stop button on the left handle forwards.

Operating

Starting a cut

- ◆ Stand in a stable position with your feet well away from the inserted tool.
- ◆ Press the machine against the working surface before you start.
- ◆ The impact unit is activated when the machine is pressed down and loaded. When the machine is lifted, the impact unit disengages automatically.
- ◆ The working speed of the machine is controlled via the throttle lever.
- ◆ Start collaring at such a distance from the edge that the machine is capable of breaking the material without levering.

- ◆ Never break off too large pieces. Adjust the breaking distance (A) so that the inserted tool does not fasten.

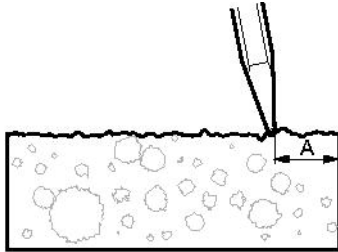

Breaking

- ◆ Never use the machine as a lever, the material should be broken by impact energy.
- ◆ If the tool fastens, never try to lift it by pulling on the top of the fuel tank.
- ◆ Check that the handle bar can move freely (up and down) without binding.
- ◆ Let the machine do the work. Never press too hard. The vibration absorbing handle should never be forced all the way to the bottom.
- ◆ The feed force should be adjusted so that the handle is pressed 'half way down'. This position provides the best vibration damping and the best breaking force.

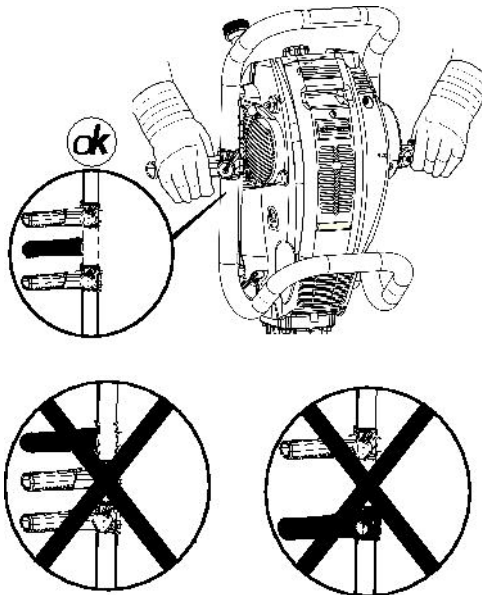

- ◆ Avoid working in extremely hard material such as granite and reinforcing iron, since such materials can cause strong vibrations.
- ◆ Avoid idling; operation without a inserted tool and operation with the machine lifted.
- ◆ Release the throttle lever when the machine is lifted.

Breaking at high altitude

To get the best result when breaking at high altitude, do the following:

- ◆ Check that the air filter is in good condition.
- ◆ If necessary, lean the fuel mix by turning the main nozzle (A) clockwise.

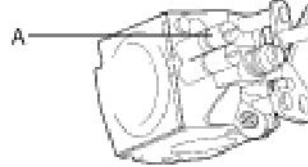

- ◆ When finished with operating at high altitude, turn back the main nozzle (A) to the default position.

Tie tamping

Cobra TT and Cobra TT-AWD are designed for tie tamping.

Tie tamping is used for local maintenance of railway tracks in an area up to 30 square meters. Tie tamping stabilizes the ballast under the sleepers.

To get the best result when tie tamping, do the following:

- ◆ Two operators must operate on each side of the sleeper. Operating on opposite sides will compress the ballast down and up, and fill all gaps and create stability.
- ◆ Lean the machine when operating. Do not operate in a straight angle, it will compress the ballast too deeply and reduce the stability.
- ◆ Operate for 2-3 seconds at one point before moving to another operating point. Operating too long time at one point will press the ballast too deeply.
- ◆ Release the throttle lever when the machine is lifted.

When taking a break

- ◆ Stop the machine during breaks.
- ◆ During all breaks you must put the machine away so that there is no risk for unintentional start.

Maintenance

Regular maintenance is a basic requirement for the continued safe and efficient use of the machine. Follow the maintenance instructions carefully.

- ◆ Before starting maintenance on the machine, clean it in order to avoid exposure to hazard substances. See "Dust and fume hazards"
- ◆ Use only authorised parts. Any damage or malfunction caused by the use of unauthorised parts is not covered by warranty or product liability.
- ◆ When cleaning mechanical parts with solvent, comply with appropriate health and safety regulations and ensure there is satisfactory ventilation.
- ◆ For major service to the machine, contact your nearest authorised workshop.
- ◆ After each service, check that the machine's vibration level is normal. If not, contact your nearest authorised workshop.

Every day

Before undertaking any maintenance or changing the inserted tool, turn the machine off.

- ◆ Perform a general inspection and check that there are no leaks and no damage.
- ◆ Check that the tool retainer is not worn and that it functions as it should. Never use the equipment if you suspect that it is damaged.
- ◆ Check that the O-ring on the oil plug is undamaged and seals properly.
- ◆ Check that the oil plug is tight regularly.
- ◆ Check for wear in the tool bush.
- ◆ Check the insertion tool, make sure that it is sharp and not worn out.
- ◆ Change damaged parts immediately.
- ◆ Replace worn components in good time.

In order to ensure that the machine remains within the stated vibration level values, the following checks must be performed:

Wear check

If a inserted tool with a worn shank is used, machine vibration will increase. Avoid such vibration by checking for shank wear before mounting the insertion tool on the machine.

- ◆ Use the shank gauge that corresponds to the dimension of the inserted tool shank. If the gauge can be inserted up to point A in the tool bush (point B) then the tool bush must be replaced immediately.

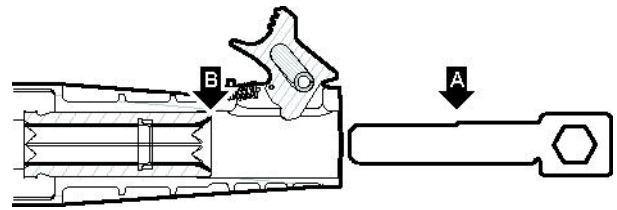

Air filter check

A clogged air filter will eventually cause damage to the engine. Check the air filter regularly.

1. Unscrew the air filter cover.
2. Tap the air filter carefully against the palm of your hand. If the air filter is very dirty, it must be replaced. Never wash the air filter.



3. Clean filter container.

Spark plug check

If the spark plug electrodes are very dirty or burnt you should replace the spark plug. You will find the spark plug under the service cover, mounted in the cylinder head. See the section "Main parts" for position of the spark plug.

Only use Champion RCJ8 and make sure that the electrode gap is 0.6-0.7 mm before fitting the spark plug.

Hammer mechanism oil check

The machine has a natural oil consumption and the oil level in the impact unit should be checked every day. The machine must be upright when performing the oil check. The oil level should be at the same height as the filling pipe.

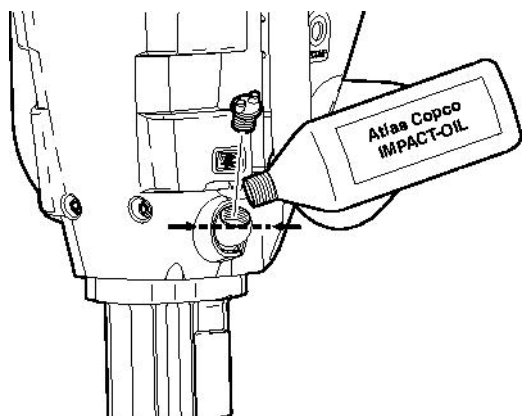

Use only Atlas Copco IMPACT-OIL.

Every month

Gearbox oil level check

Before releasing the oil plug remove the six nuts for the back cover. The level in the gearbox is checked by unscrewing the oil plug. The oil level is correct when it reaches to the bottom of the filling hole with the machine standing upright. The volume of the gearbox is 0.1 litre.

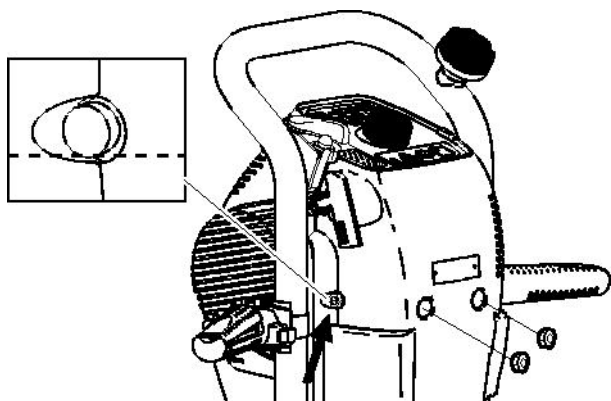

Every year

Overhauling should be done after 1 year of continuous operation. Overhauling should for safety reasons be performed by authorised personnel at an authorised workshop.

Repair

Replacing the starter cord

Removing the old starter cord

1. Remove the starting mechanism.
2. Pull out about 40 cm (16 in.) of the cord.
3. Place the starter cord in the recess (A) in the pulley.

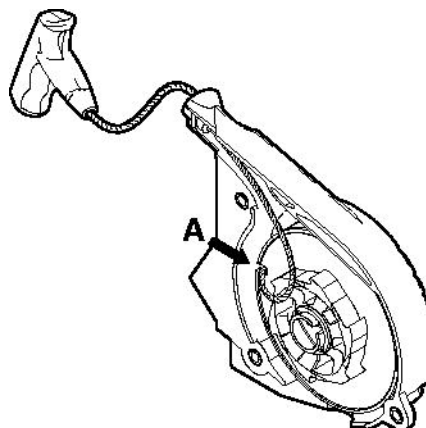

4. Rotate the pulley until all tension is released.
5. Remove the lock ring and lift out the pulley complete with spring and starter cord.

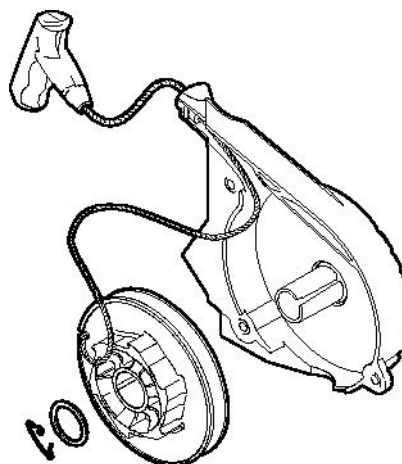

*Fitting a new starter cord*6. **▲ WARNING Spring tension**

The starter spring may cause personal injury by striking the operator or other persons.

- ▶ Wear impact resistant eye protection with side protection and gloves.

Place the knot on the starter spring in the recess on the inside of the pulley and wind in the starter spring (anti-clockwise).

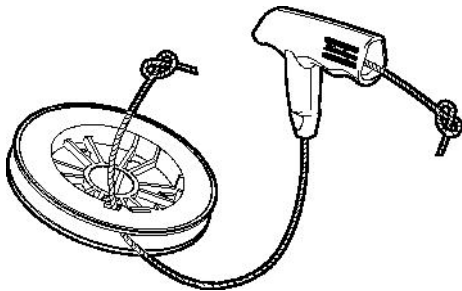

7. If the starter spring must be rewound, place the spring-hook in the pulley groove and wind on the spring anti-clockwise. If the spring must be replaced, position the spring-hook above the groove in the starter pulley. Leave the safety ring in place, press down the spring into the starter pulley.

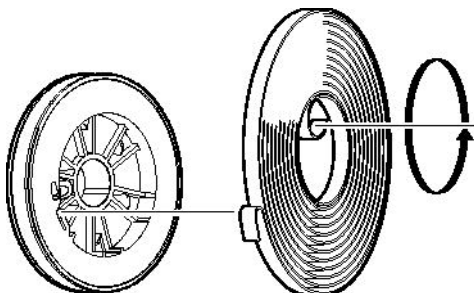

8. Wind up the starter cord onto the pulley leaving 5 cm (2 in.) of slack. Locate the end of the spring in the bushing groove, press the starter pulley onto the bushing. Replace the lock ring.

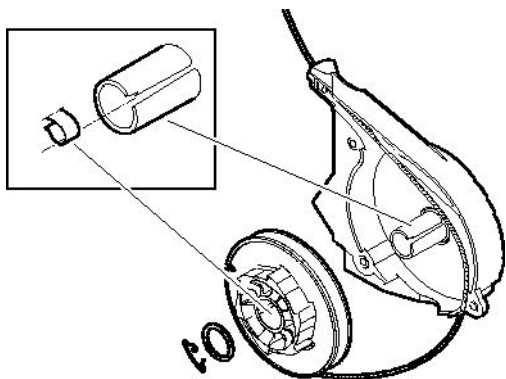
*Pre-load the starting spring*

9. Place the notch in the pulley edge in line with the starter cord guide and place the starter cord in the notch.
10. Fit the lock ring.

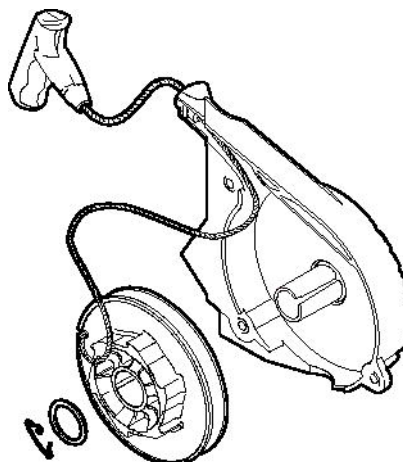

11. Rotate the pulley 1 turn anti-clockwise.
12. Release the starter cord slowly.
13. Pull on the starting handle, check the function.
14. Pull out the starter cable, at the same time grip the starter disc and check that it can be turned anticlockwise another 1/2 turn. If not, the spring has been over-tightened and is touching the bottom, the starter cable must therefore be loosened a turn.
15. Fit the starting mechanism.
16. Check the function.

Troubleshooting

If the petrol breaker does not start, has low power or runs unevenly, check the following points.

1. Check that the switch is in the ON position (A).

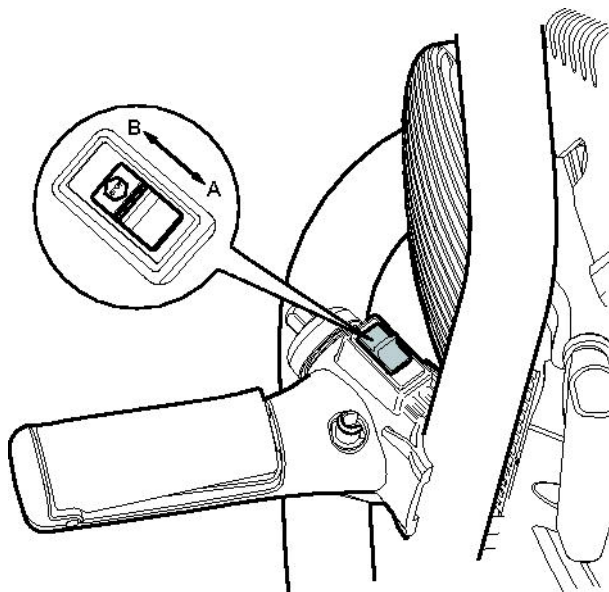

Before a petrol driven machine is deposited it must be emptied and cleaned of all oil and petrol. Remaining oil and petrol must be dealt with in a way that does not affect the environment.

2. Check that there is fuel in the tank.
3. Check that the spark plug is undamaged and that the electrode gap is 0.6–0.7 mm (0.024-0.0275 in.).
4. Check that the air filter is clean and not clogged.
5. Check that the inserted tool in use has the correct shank dimensions.

If the machine still does not function satisfactorily, contact an authorised workshop.

Storage

- ◆ Empty the tank before storing the machine.
- ◆ Check that the machine is properly cleaned before putting it away for storage.
- ◆ Store the machine in a dry place.
- ◆ We recommend to store the machine in a standing position. If stored in a lying position, the machine must be placed on the back cover.
- ◆ Keep the machine and tools in a safe place, out of the reach of children and locked up.

Disposal

A used machine must be treated and disposed of in such a way that the greatest possible portion of the material can be recycled and any negative influence on the environment is kept as low as possible, and in respect to local restrictions.

Technical data

Products

Description	Tool shank size, mm (in.)
Cobra Pro	32 x 160 (1¼ x 6¼)
Cobra Pro US	32 x 152 (1¼ x 6)
Cobra Pro AUS	28 x 160 (1⅛ x 6¼)
Cobra Pro US	28 x 152 (1⅛ x 6)
Cobra TT-AWD	32 x 160 (1¼ x 6¼)
Cobra TT	28 x 152 (1⅛ x 6)
Cobra TT	28 x 160 (1⅛ x 6¼)
Cobra TT	32 x 152 (1¼ x 6)
Cobra TT	32 x 160 (1¼ x 6¼)

Machine data

	Cobra Pro	Cobra TT, TT-AWD
Type	1 cylinder, two-stroke, fan cooled	1 cylinder, two-stroke, fan cooled
Cylinder displacement (cc)	90	90
Power kw (hp)	2.0 (2.7)	1.5 (2.0)
Full speed, loaded machine with tamping tool on bed of sand (r.p.m.)	5800–6200	6500±200
Speed, unloaded machine, idling (r.p.m.)	1800–2200	1800–2200
Max. engine speed unloaded (r.p.m.)	7500	7500
Carburettor	Diaphragm carburettor	Diaphragm carburettor
Ignition system	Transistor type, breakerless with built in speed limitation	
Spark plug (recommended)	Champion RCJ8	Champion RCJ8
Spark plug gap, mm (in.)	0.6–0.7 (0.024–0.0275)	0.6–0.7 (0.024–0.0275)
Fuel type	Petrol (gasoline), Unleaded (non-alkylat), and 90–100 octane	
Fuel tank capacity, litres (oz)	1.0 (33.81)	1.0 (33.81)
Two-stroke oil	Atlas Copco two-stroke oil, or recommended two-stroke oil	
Fuel mixture	2% (1:50)	2% (1:50)
Fuel consumption, litres/hour (gallon/hour)	0.9 (0.237)	0.8 (0.176)
Length, mm (in.)	927 (36.5)	927 (36.5)
Depth, mm (in.)	331 (13)	331 (13)
Width across handles, mm (in.)	611 (24)	611 (24)
Width with handles folded, mm (in.)	390 (15.3)	390 (15.3)
Width across machine, mm (in.)	320 (12.6)	320 (12.6)
Weight, kg (lb)	25.2 (55.6)	25.2 (55.6)
Ambient temperature C° (F)	-15 to +37 (5 to 98.6)	-15 to +37 (5 to 98.6)

Gearbox unit

	Cobra Pro	Cobra TT, TT-AWD
Oil type for gearbox	Atlas Copco IMPACT-OIL	Atlas Copco IMPACT-OIL
Gearbox oil capacity, litres (oz)	0.1 (3.38)	0.1 (3.38)

Impact unit

	Cobra Pro	Cobra TT, TT-AWD
Impact energy	60 J at 24 Hz	40 J at 27 Hz
Blows/minute	1440	1620
Frequency (Hz)	24	27
Lubrication	Impact mechanism through separate oil bath	
Oil type for impact unit	Atlas Copco IMPACT-OIL	Atlas Copco IMPACT-OIL
Oil capacity, litres (oz)	0.1 (3.38)	0.1 (3.38)
Oil consumption, litres/hour (oz/hour)	0.005 (0.17)	0.005 (0.17)

Noise and vibration declaration statement

Guaranteed sound power level **L_w** according to ISO 3744 in accordance with directive 2000/14/EC.

Sound pressure level **L_p** according to ISO 11203.

Vibration value **A** and uncertainty **B** determined according to ISO 20643. See table "Noise and vibration data" for the values of A, B, etc.

These declared values were obtained by laboratory type testing in accordance with the stated directive or standards and are suitable for comparison with the declared values of other tools tested in accordance with the same directive or standards. These declared values are not suitable for use in risk assessments and values measured in individual work places may be higher. The actual exposure values and risk of harm experienced by an individual user are unique and depend upon the way the user works, in what material the machine is used, as well as upon the exposure time and the physical condition of the user, and the condition of the machine.

We, Atlas Copco Construction Tools AB, cannot be held liable for the consequences of using the declared values, instead of values reflecting the actual exposure, in an individual risk assessment in a work place situation over which we have no control.

This tool may cause hand-arm vibration syndrome if its use is not adequately managed. An EU guide to managing hand-arm vibration can be found at <http://www.humanvibration.com/EU/VIBGUIDE.htm>

We recommend a programme of health surveillance to detect early symptoms which may relate to vibration exposure, so that management procedures can be modified to help prevent future impairment.

Additional vibration information

This information is provided to assist in making rough estimates of the vibration value in the workplace.

The vibration emission varies greatly with task and operator technique. The declared vibration value relates to the main handle(s) and much higher vibration levels may occur at other hand positions. We believe that normal intended use of the tool will usually produce vibration emissions in the range of **C_{m/s²}**, **E_{m/s²}**, and **G_{m/s²}** (vibration total values, as defined in ISO 5349-1:2001) depending on the details of the task, but emissions outside this range may occur for some applications.

A figure of **D_{m/s²}**, **F_{m/s²}**, and **H_{m/s²}** is probably a useful average emission value when, for example, roughly estimating the likely average exposures of users performing a wide range of tasks within the intended use of the tool. We point out that application of the tool to a sole specialist task may produce a different average emission and in such cases we strongly recommend a specific evaluation of the vibration emission.

Noise and vibration data

Noise		
Declared values		
	Sound pressure	Sound power
	ISO 11203	2000/14/EC
Type	Lp r=1m dB(A) rel 20µPa	Lw guaranteed dB(A) rel 1pW
Cobra Pro	96	109
Cobra TT	96	109
Cobra TT-AWD	96	109

Vibration								
Three axes values								
	Declared values		Additional vibration information					
	ISO 20643		Concrete		Asphalt		Tie tamping	
Type	A m/s ² value	B m/s ² spreads	C m/s ² range	D m/s ² ave.	E m/s ² range	F m/s ² ave.	G m/s ² range	H m/s ² ave.
Cobra Pro	4.3	0.9	4.1–5.0	4.6	3.4–3.9	3.7	-	-
Cobra TT	4.5	1.0	4.1–4.5	4.3	3.8–4.4	4.1	3.6–4.6	4.2
Cobra TT-AWD	4.5	1.0	4.1–4.5	4.3	3.8–4.4	4.1	3.6–4.6	4.2

EC Declaration of Conformity

EC Declaration of Conformity (EC Directive 2006/42/EC)

We, Atlas Copco Construction Tools AB, hereby declare that the machines listed below conform to the provisions of EC Directive 2006/42/EC (Machinery Directive) and 2000/14/EC (Noise Directive), and the harmonised standards mentioned below.

Motor breaker	Guaranteed sound power level [dB(A)]	Measured sound power level [dB(A)]
Cobra Pro	109	107
Cobra TT	109	107
Cobra TT/AWD	109	107

Following harmonised standards were applied:

- ◆ ISO/FDIS 11148-4

Following other standards were applied:

- ◆ 2000/14/EC, appendix VIII
- ◆ 2005/88/EC
- ◆ Lloyds Register Quality Assurance, NoBo no.0088

Technical Documentation authorised representative:

Erik Sigfridsson
 Atlas Copco Construction Tools AB
 Dragonvägen 2
 Kalmar

General Manager:

Erik Sigfridsson

Manufacturer:

Atlas Copco Construction Tools AB
 105 23 Stockholm
 Sweden

Place and date:

Kalmar, 2010-01-01

Warranty

This warranty only applies in the United States of America.

Emission control system warranty

Atlas Copco Construction Tools AB warrants to the initial purchaser of the machine and each subsequent owner that the engine in the machine (in Atlas Copco-brand breaker/drill models Cobra Pro, Cobra TT, Cobra Combi and in Chicago Pneumatic-brand breaker model CP Red Hawk, as applicable) meets the following two conditions: (1) the engine, including all parts of its emission control system, is designed, built, and equipped so it conforms at the time of sale to the initial purchaser with the applicable requirements in 40 CFR Part 1054 regulated by the U.S. Environmental Protection Agency; and (2) the engine, including all parts of its emission control system, is free from defects in materials and workmanship that may keep it from meeting the applicable requirements in 40 CFR Part 1054 regulated by the U.S. Environmental Protection Agency. (The above-stated warranty is referred to herein as “this Emission Control System Warranty”.) This Emission Control System Warranty covers all components whose failure would increase the engine’s emissions of any pollutant regulated by the United States Environmental Protection Agency under 40 CFR Part 1054.

The warranty period for this Emission Control System Warranty begins on the date of sale of the machine to the initial purchaser and ends two years thereafter.

Where a warrantable condition exists under this Emission Control System Warranty, warranty repairs will be made by an Atlas Copco Representative (as defined below) or by a service facility designated by the Atlas Copco Representative, without charge for diagnosis, parts, or labor, subject to all other provisions stated herein. All defective parts replaced under this Emission Control System Warranty become the property of the Atlas Copco Representative. Normal maintenance items are warranted up to their first required replacement interval only. Only Atlas Copco Construction Tools AB approved replacement parts may be used in the performance of any warranty repairs under this Emission Control System Warranty and will be provided without charge.

This Emission Control System Warranty does not extend to components or parts which are affected or damaged by the machine owner’s or any other person’s (other than Atlas Copco Construction Tools AB’s or the Atlas Copco Representative’s) improper use or improper maintenance (including, but not limited to, improper replacement of filters, sparkplugs or other maintenance items or wear parts; incorrect oil or fuel; stale or improper fuel mix; dirt or other contaminants in the fuel or oil; excessive dirt, dust, rust, or corrosion in the engine; improper storage; use of replacement parts or accessories not conforming to the original specifications which impair the effectiveness of the emission control system; incorporation of or use of unsuitable attachments or unauthorized alteration of any part; or improper repair), abuse, accident, or acts of God.

This Emission Control System Warranty does not cover replacement of expendable maintenance items (for example spark plugs and filters) unless they are original items defective in material or workmanship and the first required replacement interval (in accordance with applicable instructions published by the machine manufacturer) for the item has not been reached.

Responsibility for Maintenance:

As the machine engine owner, you are responsible for the performance, at your expense, of the proper maintenance of the engine (in addition to all other parts of the machine and accessories) in accordance with applicable instructions published by the machine manufacturer, including in the Safety and Operating Instructions manual for the machine. Atlas Copco Construction Tools AB recommends that you retain all receipts and maintenance records covering performance of maintenance. Proper maintenance includes, but is not limited to, routine replacement and servicing of spark plugs, filters, other expendable wear parts, and any other part or item related to emission control or that may affect emissions.

Requirements related to warranty claims:

Warranty repairs may only be performed by an Atlas Copco Representative or by a service facility designated by the Atlas Copco Representative to perform the warranty repair. “Atlas Copco Representative” means the dealer in the United States from whom your machine was initially purchased as a new machine or a service facility in the United States that is owned or operated by Atlas Copco Construction Equipment LLC and which performs warranty repair of such machine engines. You are responsible for promptly presenting the machine (into which the engine is incorporated) to the nearest Atlas Copco Representative as soon as a warrantable condition exists under this Emission Control System Warranty. At the time of requesting warranty repair, you must provide proof of the initial purchase of the machine, including the initial purchase date.

If you are located more than 100 miles from the nearest Atlas Copco Representative, the Atlas Copco Representative will (at its choice) (i) pay for shipping costs of the machine to and from the nearest Atlas Copco Representative; (ii) provide for a technician to come to you to make the warranty repair under this Emission Control System Warranty; or (iii) pay for the warranty repair to be made at a local service facility designated by the Atlas Copco Representative to perform the warranty repair on your machine engine under this Emission Control System Warranty. (The provisions in the preceding sentence apply only for the contiguous states, excluding the states with high-altitude areas identified in 40 CFR 1068, Appendix III.) If you are located within 100 miles of an Atlas Copco Representative, you will be responsible for paying all shipping/ transportation costs, technician travel costs if the technician comes to you, and other similar costs, unless the Atlas Copco Representative in its discretion elects to pay for such costs or any portion thereof.

If the Atlas Copco Representative determines that there is no warrantable condition under this Emission Control System Warranty, you will be responsible for the cost of the diagnosis, labor and parts in accordance with the Atlas Copco Representative's normal rates, costs of shipping/ transporting (regardless of your distance to an Atlas Copco Representative), technician travel costs if the technician comes to you, and other similar costs, unless the Atlas Copco Representative in its discretion elects to pay for such costs or any portion thereof.

For information about how to make a warranty claim and how to make arrangements for authorized warranty repair, please contact the dealer in the United States from whom your machine was initially purchased as a new machine. You may also contact Atlas Copco Construction Equipment LLC via telephone at 1-800-760-4049 or via email to aceservice@us.atlascopco.com.

General warranty conditions and limitations on liability

1.1 Atlas Copco Construction Equipment LLC warrants the above mentioned new equipment against failure due to faulty material or workmanship for a period of twelve (12) months from the date of purchase of said machine, excluding expendable wear parts. To facilitate warranty claim processing, retain a copy of the invoice as this will be needed for purchase date verification when making a request for warranty.

1.2 Should any failure under this warranty occur during the specified period under normal and proper use, and provided the equipment has been properly serviced, maintained and stored with due regard to any directions, instructions and operating procedures published by Atlas Copco Construction Equipment LLC, Atlas Copco Construction Equipment LLC shall, if given prompt notice by purchaser, through its authorized servicing facility correct such non-conformity at its option either by repair or adjustment, F.O.B. nearest service facility, or refund for the purchase price of the non-conforming equipment or part. The return of the equipment or part to Atlas Copco Construction Equipment LLC pursuant to this paragraph, shall be at the purchaser's risk and expense. Atlas Copco Construction Equipment LLC will return unit to the purchaser at Atlas Copco Construction Equipment LLC's expense. To be eligible for credit or replacement, warranty parts must be returned to Atlas Copco Construction Equipment LLC within 30 days of the original claim.

1.3 Atlas Copco Construction Tools LLC warrants parts repaired or replaced pursuant to 1.2 above under normal and proper use, storage, service and maintenance against defects in workmanship and material for a period of thirty (30) days from date of repair or adjustment or the expiration of the equipment warranty, whichever is longer.

1.4 The foregoing warranties do not apply to defects in equipment or parts caused by materials provided by the purchaser or by redesigns made by the purchaser or by repairs or alterations not authorized by Atlas Copco Construction Equipment LLC

1.5 THE FOREGOING WARRANTIES ARE EXCLUSIVE AND IN LIEU OF ALL OTHER WARRANTIES OF QUALITY, WRITTEN, ORAL OR IMPLIED, AND ALL OTHER WARRANTIES INCLUDING ANY WARRANTY OF MERCHANTABILITY OR FITNESS FOR PURPOSE ARE HEREBY DISCLAIMED.

1.6 Correction of non-conformities as provided for above shall be purchaser's exclusive remedy and shall constitute fulfillment of all liabilities of Atlas Copco Construction Equipment LLC whether in warranty, contract, negligence, tort or otherwise. Atlas Copco Construction Equipment LLC shall not be liable for any damages which a purchaser may claim arising from loss of profits or revenue, loss of use of the equipment or parts, cost of capital, cost of substitute equipment or parts, downtime costs, or claims of customers for such other damages.

1.7 Atlas Copco Construction Equipment LLC reserves the right to amend this warranty policy at any time with thirty (30) days written notification but said changes will not affect previously sold equipment, parts or tools.



Any unauthorized use or copying of the contents or any part thereof is prohibited. This applies in particular to trademarks, model denominations, part numbers, and drawings.